

Changes in force: C 1 and C 2

CHANGE }
No. 2 }

HEADQUARTERS
DEPARTMENT OF THE ARMY
WASHINGTON, D.C., 17 September 1973.

Operator's and Organizational Maintenance Manual
Including Repair Parts and Special Tools Lists
DISTRIBUTOR, WATER, COLLAPSIBLE TANK, 900 GALLON,
GRAVITY FEED (U.S. RUBBER MODEL CE-9C;2)
FSN 3825-542-2173

TM 5-3825-217-12, 1 April 1969, is changed as follows:

Page 1-1. Paragraph 1-21 is changed as follows: Report of errors, omissions, and recommendation for improving this publication by the individual user is encouraged. Reports should be submitted on DA Form 2028 (Recommended Changes to Publications) and forwarded direct to commander, U.S. Army Troop Support Command, ATTN: AMSTS-MPP 4300 Goodfellow Boulevard. St. Louis, MO 63120." Page B-1. Appendix B is rescinded.

By Order of the Secretary of the Army:

Army
Official:

VERNE L. BOWERS
Major General, United States Army
The Adjutant General

CREIGHTON W. ABRAMS
General, United States

Chief-of Staff

Distribution:

To be distributed in accordance with DA Form 12-25B (qry rqr block No. 378) organizational requirements for Distributor, Water.

CHANGE }
No. 1 }

HEADQUARTERS
DEPARTMENT OF THE ARMY
Washington, D. C., 11 January 1971

**Operator's and Organizational Maintenance Manual
Including Repair Parts and Special Tools List
DISTRIBUTOR, WATER, COLLAPSIBLE TANK, 900 GALLON,
GRAVITY FEED (U. S. RUBBER MODEL CE-9C.2)
FSN 3825-542-2173**

Current as of 2 December 1970

TM 5-3825-217-12, 1 April 1969, is changed as follows: The title is changed as shown above.
Page i, chapter 2, section III. Change title from "Control" to read "Controls and Instruments."
Page ii, chapter 4. Rescinded
Insert the following information in page column of table of contents:

Appendix A.....	A-1
B.....	B-1
C.....	C-1
D.....	D-1
Section I.....	D-1
II.....	D-2
III(Not applicable	
IV.....	D-3
Group 22.....	D-3
57.....	D-3
95.....	D-9
Section V.....	D-12

So much of paragraphs 1-3, 2-3, and 3-5 as reads "fig. 1-1" is changed to read "fig. D-1."
Page 1-1, chapter 1. Section I is superseded as follows:

Section I. GENERAL

1-1. Scope

- a. This manual contains information and instruction necessary for the operation and maintenance of the water distributor.
- b. Refer to TM 740-90-1 (Administrative Storage of Equipment) for information and instructions pertaining to organizational administrative storage.
- c. Refer to TM 750-244-3 (Procedures for Destruction of Equipment to prevent Enemy Use) for information and instructions on destruction of equipment to prevent enemy use.

1-2. Forms and Records

DA Forms and procedures used for equipment maintenance will be only those prescribed by TM 38-750, the Army Maintenance Management System.

1-2.1. Reporting of Errors

Report of errors, omissions, and recommendations for improving this publication by the individual user is encouraged. Reports should be submitted on DA Form 2028 (Recommended Changes to DA Publications) and forwarded direct to Commanding General, U.S. Army Mobility Equipment Command, ATTN: AMSME-MPP, 4300 Goodfellow Boulevard, St. Louis, Mo., 63120.

Page 1-1. Paragraph 1-3b, line 9, fourth sentence is superseded as follows: "Centered on the manhole cover is a 2-inch male threaded opening to permit connection of a 2-inch adapter, and a 25-foot section of 2-inch hose for either filling the tank with water or pumping water from the tank."

Paragraph 1-3c, line 1. Change title from "Drain Out-

let Assembly fig. 1-1)" to read "Drain Assembly (fig 1-1)".

Paragraph 1-3e, lines 6 and 7. Change "quick closing lever type brass valve" to read "globe valve".

Paragraph 1-4a. In line 3, "Valve" is changed to read "valve".

Page 1-2, paragraph 1-5, line 1. Change "Mode" to read "Model."

Page 1-3, figure 1-1, callout 13. Change "Drain base assembly " to read "Drain assembly"

Page 1-4, figure 1-2, callout 1, Change "Pipe, 65 in." to read "Pipe, 53 in."

Page 2-1, paragraph 2-1c, line 1. Change "bronze valve" to read "globe valve."

Paragraph 2-3e (5), line 4. Change "seivel" to read swivel".

Paragraph 2-4a. In line 2, "gate valve handler" is changed to read "globe valve."

Page 2-2. Change title of section III from "CONTROLS" to read "CONTROLS AND INSTRUMENTS."

Paragraph 2-7. Change title from "Controls" to read "Controls and Instruments." In the first sentence change "unitis" to read "unit is".

Paragraph 2-9a, line 4. Change "gate valve" to read "globe valve."

Paragraph 2-9b, third sentence, lines 7 and 8. Change "By pulling on the nylon rope in the cab, which opens the gate valves" to read "By pulling on the nylon rope in the cab, which opens the globe valve."

Page 3-1. Change title to chapter 3 from "OPERATOR'S ORGANIZATIONAL MAINTENANCE INSTRUICTIONS" to read "OPERATOR'S AND ORGANIZATIONAL MAINTENANCE INSTRUCTIONS."

Page 3-2, paragraph 3-8. Change title from "Troubleshootng Table" to read "Troubleshooting Table."

Page 4-1, chapter. Deleted

Page .A-1. APPENDIX A, REFERENCES, is superseded as follows:

A-1. Destruction of Equipment

TM 750-244-3 Procedures for Destruction of Equipment to Prevent Enemy Use (Mobility Equipment Command)

A-2. Maintenance

TM 38-750 The Army Maintenance Management System

A-3. Operation

TM 9-2320-209-SC Equipment Serviceability Criteria for Truck, Dump: 2½-Ton, 6 X 6, M47, M59, and M342

TM 9-2320-209-10 Operator's Manual for 2½ Ton, 6 X 6 chassis, Truck: M47, M59, and M342

A-4. Painting

TM 9-213 Painting Instructions for Field Use

A-5. Shipment and Storage

TB 740-93-2 Preservation of USAMEC Mechanical Equipment for Shipment and Storage

TM 740-90-1 Administrative Storage of Equipment

SB 740-5430-93-E01 Storage of Fabric Collapsible Water Tanks

Page C-1, section II, MAINTENANCE ALLOCATION CHART. Add an "O" in the "INSTALL" column (col. (3)G) for "Tank assembly," "Control valves," and "Spray bar."

Page D-2, paragraph 7. Below code 00333 the following is added:

Code	Manufacturer
77357	Powhatan Brass and Iron Works

Appendix D. Change the page numbers as follows:

1 to D-3	6 to D8
2 to D-4	7to D9
3 to D-5	8 to D10
4 to D6	9 to D11
5 to D7	10 to D12

Make the following changes to Appendix D:

DEPARTMENT OF THE ARMY TECHNICAL MANUAL

**OPERATOR AND ORGANIZATIONAL MAINTENANCE MANUAL
INCLUDING REPAIR PARTS AND SPECIAL TOOLS LIST
DISTRIBUTOR, WATER COLLAPSIBLE TANK;
900 GALLON; GRAVITY FEED
(U.S. RUBBER MODEL CE-9C-2) FSN 3825-542-2173**

Headquarters, Department of the Army, Washington, D.C.
1 April 1969

Current as of 13 November 1968

SAFETY PRECAUTIONS

The safety precautions to consider while operating the water distributor are those precautions associated with the vehicle used in conjunction with the water distributor.

	Paragraph	Page
CHAPTER 1. INTRODUCTION		
Section I. General		
Scope	1-1	1-1
Forms and Records.....	1-2	1-1
II. Description and Data		
Description	1-3	1-1
Identification and tabulated data	1-4	1-1
Difference in models	1-5	1-2
CHAPTER 2. INSTALLATION AND OPERATING INSTRUCTIONS		
Section I. Service upon receipt of material		
Inspection.....	2-1	2-1
Installation of separately packed components	2-2	2-1
Installation or setting up Instructions.....	2-3	2-1
II. Movement to a New Worksite		
Dismantling for movement	2-4	2-1
Installation after movement	2-5	2-1
III. Controls		
General.....	2-6	2-2
Controls	2-7	2-2
IV. Operation Under Usual Conditions		
General.....	2-8	2-2
Operation of equipment.....	2-9	2-2
V. Operation Under Unusual Conditions		
General.....	2-10	2-2
Salt Water Service	2-11	2-2
CHAPTER 3. OPERATOR'S AND ORGANIZATIONAL MAINTENANCE INSTRUCTIONS		
Section I. Operator's and Organizational Maintenance Repair Parts, Tools and Equipment		
Tools.....	3-1	3-1
Organizational maintenance repair parts	3-2	3-1
II. Preventive Maintenance Checks and Services		
General.....	3-3	3-1
Preventive maintenance checks and services	3-4	3-1
III. Operators Maintenance		
Servicing the water tank.....	3-5	3-1
Servicing the spray bar.....	3-6	3-1
IV. Troubleshooting		
General.....	3-7	3-2
Troubleshooting table.....	3-8	3-2
V. Field Expedient Repairs		
General.....	3-9	3-2
Minor leaks	3-10	3-2

This manual supersedes TM 5-3825-217-15, 31 July 1961, including all Changes

	Paragraph	Page
VI. Organizational Maintenance Procedures		
General.....	3-11	3-2
Repair of collapsible tank	3-12	3-2
Removal and installation of manhole cover assembly	3-13	3-2
Repair of spray bar assembly.....	3-14	3-3
CHAPTER 4. SHIPMENT, LIMITED STORAGE AND DEMOLITION TO PREVENT ENEMY USE		
Section I. Shipment and Limited Storage		
General.....	4-1	4-1
Dismantling for movement	4-2	4-1
Shipping the equipment.....	4-3	4-1
Storage.....	4-4	4-1
II. Demolition of Material to Prevent Enemy Use		
General.....	4-5	4-1
Demolition	4-6	4-1
APPENDIX A. REFERENCES		
B. BASIC ISSUE ITEM LIST		
C. MAINTENANCE ALLOCATION CHART		
D. REPAIR PARTS LIST		
Section I. Introduction		
II. Prescribed Load Allowance		
III. Special Tools, Test and Support Equipment for Organizational Maintenance		
IV. Repair Parts for Organizational Maintenance		
Group 22. Body Chassis or Hull and Accessory Items		
2210 Data plates		1
57. Spray Equipment Components		
5708 Tanks, valves, lines hoses, fittings		1
95. General Use Standardized Parts		
9501 Bulk material.....		7
Section V. FEDERAL STOCK NUMBER AND REFERENCE NUMBER "INDEX		

**CHAPTER 1
INTRODUCTION**

Section I. GENERAL

1-1. Scope

This manual contains information and instructions necessary for the operation and maintenance of the Water Distributor.

1-2. Forms and Records

a. DA forms and procedures used for equipment maintenance will be only those prescribed by TM 38-750, Army Equipment Record Procedures.

b. Reporting of errors, omissions, and recommendations for improving this publication by the individual user is encouraged. Reports should be submitted on DA Form 2028 (Recommended Changes to DA Publications) and forwarded direct to Commanding General, . S. Army Mobility Equipment Command, ATTN: AIMSMIE-MIPP, 4300 Goodfellow Boulevard, St. Louis, Mo. 63120.

Section II. DESCRIPTION AND DATA

1-3. Description

The water distributor unit consists of a collapsible water tank, (fig. 1-1) a gravity-fed spray bar, and all required accessories and connections :fig. 1-2;. The unit .is to be mounted on a standard military 2½ ton, dump truck, and is intended for use in dust alleviation and soil stabilization of roads and air fields.

a. *Collapsible Tank (fig.1-1).* The 900 gallon water storage tank Is constructed of synthetic rubber covered nylon cloth win molded rubber fitting assemblies on the top and the aft end.

b. *Manhole Cover Assembly.* The manhole cover assembly is an aluminum 14-inch x 20-inch rectangular cover which attaches to the molded rubber fitting located on the top of the tank. It is removable to permit access into the tank for cleaning purposes. Mounted off center on the aluminum cover is a ½ inch bronze pipe nipple fitted with a threaded pipe cap which is removed to permit passage of air during filling or draining of the tank. Centered on the manhole cover is a 2-inch male threaded opening to permit connection of a 2-inch hard rubber hose for either filling the tank with water or pumping water from the tank. Connected integrally with the 2-inch opening is a 2-inch strainer having a solid flat bottom with side opening which will permit pumping water to a depth of approximately one inch from bottom of tank.

c. *Drain Outlet Assembly (fig. 1-1).* Attached to the molded rubber fitting of the aft end of the tank is a 2-inch drain outlet for complete drainage of the tank. It is also attaching point for the spray bar assembly.

d. *Repair Kit.* An emergency repair kit is included with the collapsible tank for repairing holes, cuts, and tears in the tank wall by the use of fabric patches. The repair kit consists of:

- Cement. air curing, six 7/2 pint cans
- Brush, 1 1/2 inches wide
- Cheesecloth, bleached 36 inches wide by 18 inches long
- Coated cloth, 12 inches wide by 18 inches long
- Roller, hand, 2 inches wide, one
- Emery cloth. 180 grit, six 4 ½ Inches x 5 ½ inches sheets
- Repair instructions
- 3 inches Mechanical clamp, two
- 5 inches Mechanical clamp, one
- Gum strip. 1 inch wide, 72 inches long

e. *Spray Bar Assembly.* The spray bar assembly consists of a series of 2-inch black steel pipes perforated with ¼-inch holes spaced 3-inches apart. The two center pipes or bars are joined by a tee connection at the center to which is attached a 2-inch rubber hose which in turn is attached to the tank by a quick closing lever type brass valve. Attached to the center bars by swing joints are two outer bars which are folded inward when not in use and secured by a snap chain wrapped around the bars and held by an eye bolt welded to the top of the center bar. 'When fully extended to 180° the spray bars measure approximately 16 feet, and about 7 feet when folded. To manually control the flow of water, 20 feet of ½ inch rope is attached to the valve lever and run from the valve, through a chain hole in the truck dump, to the cab of the truck.

1-4. Identification and Tabulated Data

a. *Identification.* The tank capacity and identification is stenciled conspicuously on the tank. The torque valve Is stenciled near the manhole cover.

b. *Tabulated Data.*

Manufacturer U S. Rubber Co.

Model..... CE-9C-2

Tank dimensions and weights

Overall length 8 ft 11 in.
Overall width..... 5 ft 9 in.
Overall height 2 ft 6 in.
Net weight empty..... 417 lb. estimated
Net weight full..... 7617 lb. Estimated
Shipping Volume 51.045 cu. Ft
Shipping Weight 475 lb.
Shipping Dimensions..... 87.75 in. x 49.50 in. x 19.62 in.

1-5. Difference in Models

In the U.S. Rubber Co. Mode CE-9C-2 is the only model covered in this manual. Serial numbers 1 thru 10 have 580 gallon capacity. All other serial numbers have 900 gallon capacity.

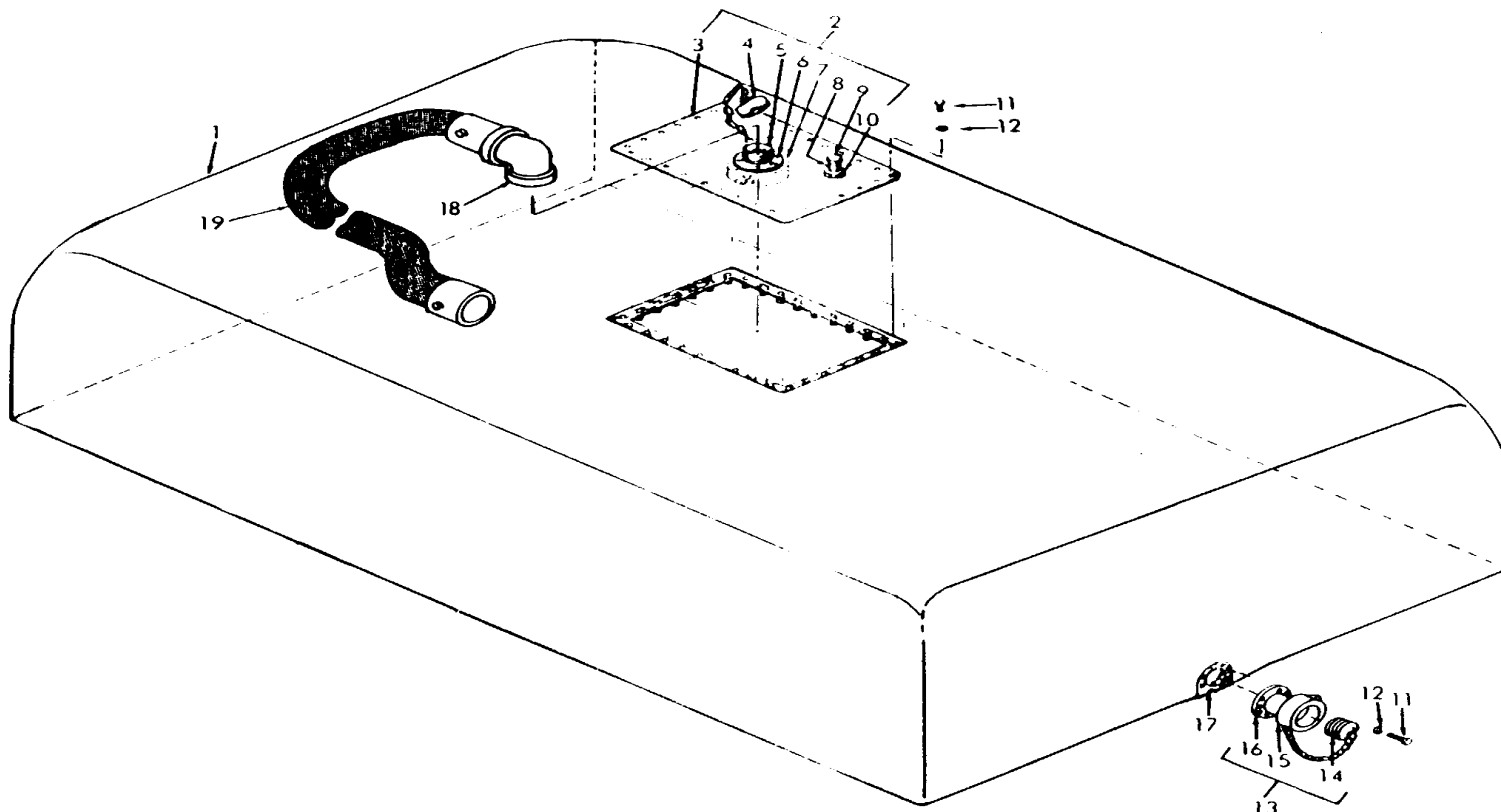

ME 3825-217-15/1-1

- | | | | |
|----|------------------------|----|-----------------------|
| 1 | 900 gallon water tank | 11 | Capscrew |
| 2 | Manhole cover assembly | 12 | Washer |
| 3 | Manhole cover | 13 | Drain base assembly |
| 4 | Cap with chain | 14 | Plug |
| 5 | Male fitting | 15 | Union |
| 6 | Machine screw #10-24 | 16 | Drain base |
| 7 | Strainer | 17 | Drain support fitting |
| 8 | Tank nipple | 18 | Elbow |
| 9 | Cap | 19 | Hose, cotton |
| 10 | Locknut | | |

Figure 1-1. Collapsible tank with hardware

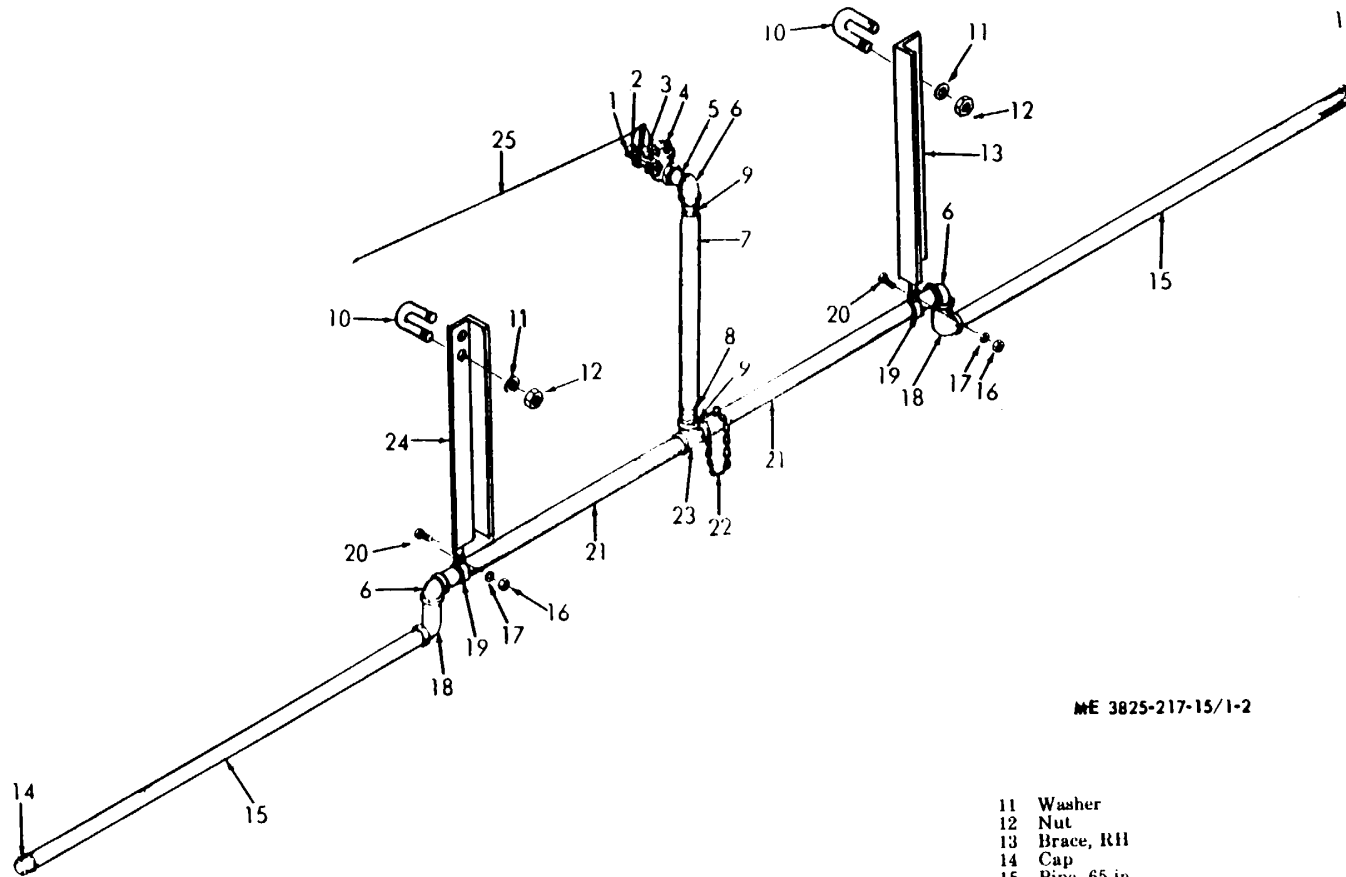

ME 3825-217-15/1-2

- 1 Adapter
- 2 Union
- 3 Nipple, 2 in.
- 4 Valve
- 5 Nipple, 3 in.
- 6 Elbow
- 7 Hose, rubber
- 8 Clamp, hose
- 9 Nipple, 5 in.
- 10 "U" bolt

- 11 Washer
- 12 Nut
- 13 Brace, RH
- 14 Cap
- 15 Pipe, 65 in.
- 16 Nut
- 17 Washer
- 18 Elbow
- 19 Clamp
- 20 Capscrew
- 21 Spray bar
- 22 Chain
- 23 Tee
- 24 Brace, LH
- 25 Nylon rope

Figure 1-2. Spray bar assembly.

CHAPTER 2

INSTALLATION AND OPERATING INSTRUCTIONS

Section I. SERVICE UPON RECEIPT OF MATERIAL

2-1. Inspection

Upon receipt of equipment a visual inspection of the shipping container and the contents should be made for obvious damage due to handling or shipping. Lay out the tank hose, repair kit, and the spray bar assembly, which are individually wrapped, and check for completeness.

- a. Inspect tank walls and hoses for any tears or punctures.
- b. Check piping and hose for visual evidence of cracks or damage, loose connections, or missing parts. Check swing joints for ease of operation by moving the outer bars outward from their folded position.
- c. Check operation of the bronze valve by manually operating the lever. The lever should return to the closed position. Remove paint from valve stem.

2-2. Installation of Separately Packed Components

There are no separately packed components.

2-3. Installation or Setting Up Instructions

- a. The collapsible tank is to be positioned in the bed of a standard 21S z ton dump truck. Sweep the truck bed thoroughly, removing sticks, stones. Or other sharp objects that could damage the tank.
- b. Lower the tail gate of the truck to facilitate loading the collapsible tank.
- c. Remove the tank from its compartment in the container, unwrap, and position the tank on the truck bed with the manhole cover facing up and the outlet fitting facing aft. The tank weighs 251 pounds and can be loaded by a four man crew.
- d. Save the shipping container for subsequent storage and shipment.
- e. Assemble the spray bar unit (fig. 1-2).

(1) Remove spray bar unit from shipping container. Keep the end bars in the folded position for handling ease.

(2) With the spray bar assembled in the configuration shown in figure 1-2, lift the unit to the dump truck. Raise the tail gate of the dump truck to the horizontal position and secure with the chain. To secure the spray bar to the dump truck, slide the "U" bolt over the rod at both ends of the most rearward edge of the tail gate, then position the spray bar braces (13) so the "U" bolt protrudes through the two drilled holes in each brace, secure the braces to the "U" bolts using the nuts (12) and washers (11) provided.

Note: All nuts, lockwashers, screws and other hardware are provided in a separate package attached to the shipping container.

(3) Remove the valve (4) from the shipping container and insert nipple (9) into one end of the rubber hose (7). Tighten the attached hose clamp (8) with a screwdriver.

Note. Do not lubricate the hose (7) to slip it on the valve nipple or spray bar tee with anything except plain water.

(4) Slip the opposite end of the rubber hose (7) over the nipple in the vertical end of the tee (23) on the spray bar (21) and tighten as above.

Note. The valve should rest on the bed of the dump truck at this point in line with the drain support on the water tank. Adjustments assure this can be obtained by adjusting the rubber hose on the valve nipple and spray bar tee accordingly before tightening the hose clamps.

(5) Remove the plug (14) figure 1-1, from the union (15) and line up the valve (4) figure 1-2 and the union (2) with the swivel on the drain assembly (13, fig. 1-1). Tighten the seivel to the union.

(6) Check the ease of movement of the spray bar ends by swinging them in line with the rest of the assembly. Swing the spray bar ends back and secure them with snap chain hooked to the welded eye on top of the pipe.

Note. Spray bar ends should be secured for road travel to and from the water point

(7) Attach the nylon rope to the arm of the valve and route it through the chain hole to the truck cab. Check ease of valve operation.

Section II. MOVEMENT TO A NEW WORKSITE**2-4. Dismantling for Movement**

- a. Drain the water distributor unit by pulling the nylon rope attached to the gate valve handle. The valve will open allowing the tank to drain through the spray bars.
- b. Dismantle the spray bar assembly by reversing procedure prescribed in paragraphs 2-3e(1) through 2-3e(7).
- c. Disconnect the valve unit and remove the handle. Store these items in the box provided for them.
- d. Fold the tank to a compact size with all components assembled to it and wrap in protective paper.
- e. Repack repair kit in its separate compartment of the shipping container.

2-5. Reinstallation After Movement

Refer to installation or setting up instructions.

Section III. CONTROLS

2-6. General

This section provides the operator crew sufficient information to insure proper operation of the water distributor.

2-7. Controls

The water distributor unit is operated from the cab of the truck. A manila rope extends from the truck cab to a handle on the valve (4, fig. 1-2). The valve is spring loaded in the closed position and is opened by pulling the rope attached to the valve handle. For instructions regarding the controls and instruments of the dump truck, refer to TM 9-2320-209-ESC/2.

Section IV. OPERATION UNDER USUAL CONDITIONS

2-8. General

- a. The instructions in this section are published for the information and guidance of personnel responsible for the operation of the water distributor.
- b. Tighten spray bars at the beginning of each operation.

2-9. Operation of Equipment

- a. Water spreading is the primary function of the water distributor. It involves the use of the spray bar to spread water over a given area. Water is gravity fed from the tank through the gate valve and perforated holes in the spray bar.
- b. While traveling to and from the area to be sprayed, the steel pipe extensions on the spray bar assembly are folded inward. To set up for operation when arriving at the job site, unwrap chain, swivel out the steel pipe at 180°, and secure the length of chain to the eyebolt on the center pipe. By pulling on the nylon rope in the cab, which opens the gate valves, water will begin to flow to and out of the spray bars. The amount of coverage will be determined by the speed of the truck. For best results the speed should not exceed 5 miles per hour.

Section V. OPERATION UNDER UNUSUAL CONDITIONS

2-10. General

Normally the equipment will not be operated during temperatures below freezing (+32°F.). Under certain conditions (moderate temperatures during the day and below freezing at night) the equipment, if assembled on the dump truck, must be protected for short intervals. This protection consists of removing any water that remains in the tank or piping to prevent its freezing.

Caution: Do not attempt to install or remove collapsible water tank if temperature is below -20°F because tank will be stiff and difficult to roll and unroll. Permanent damage to the tank could result.

2-11. Salt Water Service

After any operation involving the use of salt water in the tank and pipes, flush the drain system with clean fresh water.

CHAPTER 3

OPERATOR'S ORGANIZATIONAL MAINTENANCE INSTRUCTIONS

Section I. OPERATOR'S AND ORGANIZATIONAL MAINTENANCE REPAIR PARTS, TOOLS AND EQUIPMENT

3-1. Tools

No special tools are required for the operation or maintenance of the water distributor.

3-2. Organizational Maintenance Repair Parts

Organizational maintenance repair parts are listed in Appendix D of his manual.

Section II. PREVENTIVE MAINTENANCE CHECKS AND SERVICES

3-3. General

To insure that the water distributor is ready for operation at all times, it must be inspected systematically to detect and correct defects which could result in damage or failure of the unit. Preventive maintenance checks and services are described in paragraph 3-4. The item numbers indicate the sequence of minimum inspection requirements. Defects discovered during operation of the unit will be noted for future correction to be made as soon as the operation has ceased. Stop operation immediately if a deficiency is noted which would damage the equipment if operation of the unit were continued. All deficiencies and shortcomings will be recorded together with the corrective action taken on DA Form 2404 at the earliest opportunity.

Table 3-1 Preventive Maintenance Checks and Services

Item Number	Interval					Org. M Q	B-Before Operation D-During Operation	A-After Operation W-Weekly	M-Monthly Q-Quarterly	Reference
	Operator Daily				M		Q	Item to be inspected	Procedure	
	B	D	A	W						
1		X			X		Tank	Add water as required, check for leaks, cuts, or other damage.		
2		X			X		Spray Bar	Clean clogged spray bar holes.		
3		X			X		Spray Bar Swivel	Check for ease of movement.		
4		X			X		Spray Bar Mounting	Tighten a loose mounting.		
5		X			X		Hose	Inspect for leaks, cracks, or other damage. Replace as required.		
6		X			X		Valve	Check for free operation.		
7					X		Tank	Check for leaks, cuts, or other damage., replace or repair as required.		
8					X		Strainer	Check torque for manhole cover attaching bolts; 25 to 35 inch-pounds.		
9					X		Spray Bar	Clean clogged holes. Replace damaged spray bar.		
10					X		Spray Bar Swivel	Check for damage and replace as required.		
11					X		Valve	Check for leaks and operation. Replace defective valve.		

3-4. Preventive Maintenance Checks and Services

Table 3-1 lists the preventive maintenance checks and services required in support of water distributor.

Section III. OPERATOR'S MAINTENANCE

3-5. Servicing the Water Tank

Add water, as required, to the tank through hose (19, fig. 1-1). Check tank and spray bar assembly for leakage.

3-6. Servicing the Spray Bar

Remove any obstruction from the holes in spray bar to provide a uniform distribution of water.

Section IV. TROUBLESHOOTING

3-7. General

This section provides information useful in diagnosing and correcting unsatisfactory operation or failure of the water distributor and its components. The malfunction listed below is followed by a list of probable causes of the trouble. The corrective action recommended is described opposite the probable cause.

3-8. Troubleshooting Table

<i>Malfunction</i>	<i>Probable Cause</i>	<i>Corrective Action</i>
Little or no water from the spray bar	a. Valve closed b. Tank empty c. Perforated pipe clogged d. Tank leaks e. Hose cut	a. Open valve b. Fill tank. c. Clean holes. d. Repair tank e. Replace hose

Section V. FIELD EXPEDIENT REPAIRS

3-9. General

Operator troubles may occur while the water distributor is operating in the field where supplies and repair parts are not available and normal corrective action cannot be performed. When this condition exists the following expedient repair may be used in emergencies, upon the decision of the unit commander. Equipment so repaired must be removed from operation as soon as possible and properly repaired before being placed in operation again.

3-10. Minor leaks (Tank)

<i>Trouble</i>	<i>Expedient Repair</i>
Minor leak	Temporary repairs to the tank are accomplished by using the 3 inch and 5 inch clamps furnished in the repair kit.

Section VI. ORGANIZATIONAL MAINTENANCE PROCEDURES

3-11. General

This section will deal with the repair of the collapsible water tank and the spray bar assembly.

3-12. Repair of Collapsible Tank

The repair kit supplied with the distributor assembly is to be used for the repair of the collapsible tank.

a. Preparation of Tank.

(1) It is preferable to repair the tank indoors, but if this is not possible work should be done only in clear weather in a sheltered area free of gusts and blowing dirt or sand.

(2) The work area should be cleared and the tank should be laid on a clean, flat surface with the damaged area exposed to view for ease of workmanship.

(3) All water shall have been removed and then damaged area completely dried.

b. Repair of Tank.

(1) All repairs will be made on the outside of the tank.

(2) Cut a piece of the coated cloth large enough to lap the damaged area at least two inches.

(3) Repairs will be limited to cuts, punctures and tears up to 12 inches in length.

(4) Using the Emery cloth in the kit, lightly buff the entire area surrounding the damage over which the patch will be placed, making sure that the buffed area is at least as large as the patch.

(5) Using the Emery cloth, lightly buff the patch on one side. This will be the side which will be placed buffed side down on the damage.

(6) Both the patch and the damaged area should be wiped clean with the cheesecloth provided to remove particles of sandpaper grit and buffed rubber articles.

(7) Dip the brush in the cement and paint both the patch and the damaged area of the tank with two coats of the cement, waiting 15 minutes between the first and the second coat.

(8) When the cement feels tacky, apply the patch to the damaged area in the manner prescribed below. If the tackiness has disappeared before the patch is applied, paint both patch and the damaged area with another light coat of cement.

(9) Center the patch over the damage and using the roller from the kit, work from the center outward to avoid trapping air between the patch and the tank area.

(10) Using the roller, go over the entire patch area rolling in one direction with good pressure.

(11) Allow the repaired areas to dry at least 72 hours before using the tank. It would be desirable to lay a 25 pound shot bag or sand bag over the patch during this time.

(12) If the patch appears loose or air is trapped under it the entire repair procedure should be repeated, using a new piece of patch material and with the original cement removed from the tank. This can be done by buffing off with the Emery cloth from the kit.

3-13. Removal and Reinstallation of Manhole Cover Assembly

a. General. In order to gain access to the interior of the collapsible tank for cleaning and inspection,

it is necessary to remove the manhole cover located on top of the tank.

b. Removal

- (1) Lay tank on flat smooth surface, with protection between the tank and the ground or underlying surface.
- (2) Use extreme caution when stepping on tank.
- (3) Using a torque wrench or box wrench of the proper size, back off the 32 hex head cap screws and washers.
- (4) The screws and washers should be saved for reinstallation.
- (5) Remove the cover by grasping the pipe caps and lifting up. Store the cover in a safe, clean place.

Caution: Do not attempt to remove the cover by inserting a screwdriver between the cover and the rubber molded fitting. This will damage the fitting.

(6) It should never be necessary to remove the strainer fitting from the center of the manhole cover in order to look inside the tank. Rather, the entire cover should always be removed.

c. Installation.

(1) Make sure that the rubber fitting is clean and dry and that the bottom side of the manhole cover around the bolt holes is also clean and dry.

(2) Position the cover over the fitting in the tank so that the bolt holes line up properly, and then insert screws and washers and bring up finger tight.

(3) Using a torque wrench, proceed to tighten up each screw to a torque reading of 25 to 35 inch pounds. Screws should be tightened in a pattern by tightening the screw across the cover from it.

(4) After all the screws have been brought up to the required torque, go around the cover once more, checking to see that this torque is present.

DO NOT RETIGHTEN AFTER THIS.

Note. The above procedure can also be used for removal and reinstallation of the drain base fitting.

3-14. Repair of Spray Bar Assembly

- a.* Close valve (4, fig. 1-2)
- b.* Disassemble the spray bar until the damaged part is removed. Refer to figure 1-2.
- c.* Replace damaged part with a serviceable or new part.
- d.* Reassemble the spray bar.

CHAPTER 4

SHIPMENT, LIMITED STORAGE AND DEMOLITION TO PREVENT ENEMY USE

Section I. SHIPMENT AND LIMITED STORAGE

4-1. General

The water distributor is provided with a container that accommodates the collapsible tank and spray bar assembly. The container is used for storing and transporting the water distributor.

4-2. Dismantling for Movement

Refer to paragraph 2-4 for instructions to dismantle the water distributor.

4-3. Shipping the Equipment

- a. Load the water distributor on the conveyance.
- b. Guard against shifting of the water distributor during transit by the use of tie downs and blocks.

4-4. Storage

- a. Drain the collapsible tanks and spray bar assembly thoroughly.
- b. Fold the tank carefully until it will fit into its shipping container.
- c. Store the spray bar assembly in the shipping container.

Caution: Do not store water distributor where it will be exposed to temperatures of 32°F or colder.

Section II. DEMOLITION OF MATERIEL TO PREVENT ENEMY USE

4-5. General

When capture or abandonment of the water distributor to an enemy is imminent, the responsible unit commander must make the decision either to destroy the equipment or render it inoperative. The demolition of the equipment must insure destruction of the same parts in all equipment to prevent repair by salvage.

4-6. Demolition

Use sledge hammers, crowbars, picks, axes or any impact or cutting tool to destroy the water distributor. Smash the valve and spray bars and cut, tear or otherwise render the collapsible tank incapable of holding water.

**APPENDIX A
REFERENCES**

A-1. Painting

TM 9-213

Painting Instructions for Field Use

A-2. Maintenance

TM 38-750

Army Equipment Record Procedure

A-3. Shipment and Storage

TB 740-93-2

Preservation of USAMEC Mechanical Equipment for Shipment
and Storage

TM 740-90-1

Administrative Storage of USAMEC Mechanical Equipment

SB 740-5430-93-EO1

Storage of Fabric Collapsible Water Tanks

**APPENDIX B
BASIC ISSUE ITEMS LIST**

Section I. INTRODUCTION

B-1. Scope

This appendix lists items which accompany the water distributor, or are required for installation, operation, or operator's maintenance.

B-2. General

This Basic Issue Items List is divided into the following sections:

- a. *Basic Issue Items- Section II.* A list of items which accompany the water distributor or are required for the installation, operation, or operator's maintenance of the item required.
- b. *Maintenance and Operating Supplies - Section III.* Not applicable.

B-3. Explanation of Columns

The following provides an explanation of columns in the tabular list of Basic Issue Items, Section II.

- a. *Source, Maintenance, and Recoverability Codes (SMR), Column (1).*

Note. Common hardware items known to be readily available in Army supply will be assigned Maintenance Codes only. Source Codes, Recoverability Codes, and Quantity Authorized will not be assigned to this category of items.

- (1) Source Code, indicates the selection status and source for the listed item. Source code is:

Code	Explanation
P	Applied to repair parts which are stocked in or supplied from GSA/DSA or Army supply system, and authorized for use at indicated maintenance level.

- (2) Maintenance Code, indicates the lowest level of maintenance authorized to install the listed item.

The maintenance level code is:

Code	Explanation
C.....	Operator/crew

- (3) Recoverability Code, indicates whether unserviceable items should be returned for recovery or salvage. Items not coded are expendable.

- b. *Federal Stock Number, Column (2).* This column indicates the Federal stock number for the item.
- c. *Description, Column (3).* This column indicates the Federal item name and any additional description of the item required.
- d. *Unit of Issue, Column (4).* This column indicates the unit used as a basis for issue, e.g., ea, pr, ft, yd, etc.
- e. *Quantity Incorporated in Unit Pack, Column (5).* This column not applicable.
- f. *Quantity Incorporated in Unit, Column (6)* This column not applicable.
- g. *Quantity Furnished with Equipment, Column (7).* This column indicates the quantity of an item furnished with the equipment.
- h. *Quantity Authorized, Column (8).* This column indicates the quantity of an item authorized the operator/crew to have on hand or to obtain as required. As required items are indicated with an asterisk.
- i. *Illustration, Column(9).* This column is not applicable.

Section II. BASIC ISSUE ITEMS LIST

(1) SMR code			(2) Federal stock No.	(3) Description	(4) Unit of Meas	(5) Qty Inc in unit pack	(6) Qty inc in unit	(7) Qty furn with equip	(8) Qty auth	(9) Illustration	
(A)	(B)	(C)								(a) Figure no.	(b) Item no.
S	M	R									
P	C		7510-889-3494	GROUP 31. BASIC ISSUE ITEMS MANUFACTURER INSTALLED							
P	C		7520-559-9618	3100 - Basic Issue Items, Manufacturer or Depot Installed							
P	C		3825-798-1144	BINDER: Looseleaf	EA			1	1		
				CASE: Operation and Maintenance Manuals	EA			1	1		
				DA TECHNICAL MANUAL - TM 5-3825-217-12.....	EA			1	1		
				REPAIR KIT	EA			1	1		

APPENDIX C

MAINTENANCE ALLOCATION CHART

Section I. INTRODUCTION

C-1. General

a. This section provides a general explanation of all maintenance and repair functions authorized at various maintenance levels.

b. Section II designates overall responsibility for the performance of maintenance functions on the identified end item or component. The implementation of the maintenance functions upon the end item or component will be consistent with the assigned maintenance functions.

c. Section III is not applicable.

d. Section IV is not applicable.

C-2. Explanation of Columns in Section II

a. *Group Number, Column (1).* The functional group is a numerical group set up on a functional basis. The applicable functional grouping indexes (Codes) are listed on the MNAC in the appropriate numerical sequence. These indexes are normally set up in accordance with their function and proximity to each other.

b. *Functional Group, Column (2).* This column contains a brief description of the components of each functional group.

c. *Maintenance Functions, Column (3).* This column lists the various maintenance functions (A through K) and indicates the lowest maintenance category authorized to perform these functions. The symbol designations for the various maintenance categories are as follows:

C - Operator or crew

O - Organizational maintenance

F - Direct support maintenance

H - General support maintenance

D - Depot maintenance

The maintenance functions are defined as follows:

A Inspect: To determine serviceability of an item by comparing its physical, mechanical, and electrical characteristics with established standards.

B Test: To verify serviceability and to detect electrical or mechanical failure by use of test equipment.

C Service: To clean, to preserve, to charge, to paint, and to add fuel, lubricants, cooling agents, and air.

D Adjust: To rectify to the extent necessary to bring into proper operating range.

E Align: To adjust specified variable elements to an item to bring to optimum performance.

F Calibrate: To determine the corrections to be made in the readings of instruments or test equipment used in precise measurement. Consists of the comparison of two instruments, one of which is a certified standard of known accuracy, to detect and adjust any discrepancy in the accuracy of the instrument being compared with the certified standard.

G Install: To set up for use in an operational environment such as an emplacement, site, or vehicle.

H Replace: To replace unserviceable items with serviceable assemblies, subassemblies, or parts.

I Repair: To restore an item to serviceable condition. This includes, but is not limited to, inspection, cleaning, preserving, adjusting, replacing, welding, riveting, and strengthening.

J Overhaul: To restore an item to a completely serviceable condition as prescribed by maintenance serviceability standards using the Inspect and Repair Only as Necessary (IROAN) technique.

K Rebuild: To restore an item to a standard as nearly as possible to original or new condition in appearance, performance, and life expectancy. This is accomplished through complete disassembly of the item, inspection of all parts or components, repair or replacement of worn or unserviceable elements (items) using original manufacturing tolerances and specifications, and subsequent reassembly of the item.

d. *Tools and Equipment, Column (4).* This column is provided for referencing by code the special tools and test equipment, (sec. III) required to perform the maintenance functions (sec. II).

e. *Remarks, Column (5).* This column is provided for referencing by code the remarks (sec. IV) pertinent to the maintenance functions.

Section II. MAINTENANCE ALLOCATION CHART

(1)	(2)	(3) MAINTENANCE FUNCTIONS											(4)	(5)
GROUP NO.	FUNCTIONAL GROUP	a	b	c	d	e	f	g	h	i	j	k	TOOLS AND EQUIPMENT	REMARKS
		I N S P E C T	T E S T	S E R V I C E	A D J U S T	A L I G N	C A L I B R A T E	I N S T A L L	R E P L A C E	R E P A I R	O V E R H A U I	R E B U I L D		
57	SPRAY EQUIPMENT COMPONENTS													
5708	Tanks, Valves, Lines, Hoses, Fittings and Liquid Strainer													
	Tank assembly.....			C					0	0				
	Control valves								0	0				
	Spray bar.....			C					0	0				

**APPENDIX D
REPAIR PARTS LIST**

Section I. INTRODUCTION

D-1. Scope

This appendix lists repair parts required for the performance of organizational maintenance of the water distributor.

D-2. General

a. The repair parts list is arranged as follows:

(1) Individual parts and major assemblies are listed alphabetically by item name within the numbered functional groups.

(2) Assembly components and subassemblies are indented and listed alphabetically by item name under major assemblies.

b. This Repair Parts and Special Tools List is divided into the following sections:

(1) *Prescribed Load Allowance (PLA) - Section II.* A consolidated listing of repair parts quantitatively allocated for initial stockage at the organizational level. This is a mandatory minimum stockage allowance.

(2) *Special Topics, Test and Support Equipment -Section III.* "NOT APPLICABLE"

(3) *Repair Parts - Section IV.* A list of repair parts authorized for the performance of maintenance at the organizational level.

(4) *Federal Stock Number and Reference Number Index - Section V.* A list of Federal stock numbers followed by reference numbers, appearing in all the listings, in ascending alphanumeric sequence cross-referenced to index number.

D-3. Explanation of columns

The following provides an explanation of columns in the tabular lists in sections II through V.

a. *Source, Maintenance, and Recoverability Codes (SMR).*

Note. Common hardware items known to be readily available in Army supply channels will be assigned Maintenance codes only. Source codes, Recoverability codes, and Maintenance Allowances will not be assigned to this category.

(1) *Source Code.* Indicates the selection status and source for the listed item. Source codes used are:

Code	Explanation
P	Applied to repair parts which are stocked in or supplied from DSA/GSA or Army supply system, and authorized for use at indicated categories.
M	Applied to repair-parts which are not procured or stocked but are to be manufactured at indicated maintenance categories.
X1	Applied to repair parts which are not procured or stocked, the requirement for which will be supplied by use of the next higher assembly or components.
X2	Applied to repair parts which are not stocked. The indicated maintenance category requiring such repair parts will attempt to obtain them through cannibalization; if not obtainable through cannibalization, such repair parts will be requisitioned with supporting justification through normal supply channels.

(2) *Maintenance Code.* Indicates the lowest category of maintenance authorized to install the listed item. The maintenance level codes are:

Code	Explanation
O	Organizational maintenance

(3) *Recoverability Code.* Not applicable.

b. *Federal Stock Number.* Indicates the Federal stock number for the item.

c. *Description.* Indicates the Federal item name and any additional description of the item required. A part number or other reference number is preceded by the applicable five-digit Federal supply code for manufacturers in parentheses.

d. *Unit of Issue.* Indicates the unit used as a basis for issue, e.g., ea, pr, ft, yd, etc.

e. *Quantity incorporated in Unit Pack.* Indicates the actual quantity contained in the unit pack.

f. *Quantity Incorporated in Unit.* Indicates the quantity of the item used in the functional group.

g. *Fifteen-Day Organizational .Maintenance Allowances.*

(1) The allowance columns are divided into four subcolumns. Indicated in each subcolumn opposite the first appearance of each item is the total quantity of items authorized for the number of equipments supported. Subsequent appearances of the same item will have no entry in the allowance columns but will have in the description column a reference to the first appearance of the item. Items authorized for use as required but not for initial stockage are identified with an asterisk in the allowance column.

(2) The quantitative allowances for organizational level of maintenance represents one initial prescribed load for a 15-day period for the number of equipments supported. Units and organizations authorized additional prescribed loads will multiply the number of prescribed loads authorized by the number of prescribed loads authorized by the quantity of repair parts reflected in the appropriate density column to obtain the total quantity of repair parts authorized.

(3) Organizational units providing maintenance for more than 100 of these equipments shall determine the total quantity of parts required by converting the equipment quantity to a decimal factor

by placing a decimal point before the next to last digit of the number to indicate hundredths, and multiplying the decimal factor by the parts quantity authorized in the 51-100 allowance column. Example, authorized allowance for 51-100 equipments is 12; for 140 equipments multiply 12 by 1.40 or 16.80 rounded off to 17 parts required.

(4) Subsequent changes to allowances will be limited as follows: No change in the range of items is authorized. If additional items are considered necessary, recommendation should be forwarded to U. S. Army Mobility Equipment Command for exception or revision to the allowance list. Revisions to the range of items authorized will be made by this Command based upon engineering experience, demand data, or TAERS information.

h. Illustration.

(1) Figure number. Indicates the figure number of the illustration in which the item is shown.

(2) Item number. Indicates the callout number used to reference the item in the illustration.

4. Special Information

a. Repair parts mortality has been based on 500 hours of operation per year.

b. Parts which require manufacture or assembly at a category higher than that authorized for installation will indicate in the source column the higher category.

5. How to Locate Repair Parts

a. When Federal Stock Number or reference number is unknown:

(1) First. Using the table of contents, determine the functional group or subgroup within which the repair part belongs. This will refer to a page in the parts listing.

(2) Second. The illustration column of the page refers to a figure number.

(3) Third. Locate the figure and identify the repair parts, noting the item number.

(4) Fourth. Refer back to the page of the parts listing. Find the item number in the illustration column that corresponds with the figure number.

b. When Federal Stock number or reference number is known:

(1) First. Using the Index of Federal Stock Numbers and Reference Numbers, find the pertinent Federal stock number or reference number. This index is in ascending alphanumeric sequence cross-referenced to an index number.

(2) Second. Using the Repair Part Listing, find the index number referenced in the Index of Federal Stock Numbers and Reference Numbers.

6. Abbreviations

ft.....feet
ea.....each
in.....inch
lbpound
deg..... degree
rhright hand
lg.....long
gal..... gallon
thd..... thread
id..... inside diameter
od.....outside diameter
thk..... thick
pt..... pint
w. wide
diadiameter

7. Federal Supply Codes for Manufacturers

Code	Maintenance
00333.....	United States Rubber Co. Fuel Cell Division of Footwear and General Products Div
81336.....	Chief of Engineers
89616.....	United States Rubber Co.
96906.....	Military Standards
97403.....	Engineer Research and Development Laboratory

Federal stock no.	Description useable on code	Qty inc in unit pack	15-day org maint.alw			
			(A) 1-5	(B) 6-20	(C) 21-50	(D) 51-100
3825-798-1134	GROUP 57 - SPRAY EQUIPMENT 5708 - TANKS, VALVES, LINES, HOSES, FITTINGS GASKET:filler cap		2	2	4	8
3825-798-1144	REPAIR KIT, COLLAPSIBLE FABRIC TANK GROUP 95 - GENERAL USE STANDARD PARTS 9501 - BULK MATERIAL					2
4020-965-0378	ROPE, NYLON		2	5	10	21
4720-189-2787	HOSE, RUBBER				2	2

D-2

(1) SMR CODE	(2) FEDERAL STOCK NUMBER	(3) DESCRIPTION REFERENCE NUMBER & MFR CODE USABLE ON CODE		U/I	(4) UNIT OF MEAS	(5) QTY. INC IN UNIT	(6) 15-DAY ORGANIZATIONAL MAINTENANCE ALW				(7) ILLUSTRATION	
							(a)	(b)	(c)	(d)	(a)	(b)
							1-5	6-20	21-50	51-100	FIGURE NO.	ITEM NO.
00001		SECTION IV - REPAIR PARTS FOR ORGANIZATIONAL MAINTENANCE										
00001A		GROUP 22-BODY CHASSIS OR HULL AND ACCESSORY ITEMS										
00001B		2210 - DATA PLATES										
X20 00002	9905-807-3715	PLATE, IDENTIFICATION		EA		1						
00003		GROUP 57 - SPRAY EQUIPMENT COMPONENTS										
00003A		5708 - TANKS, VALVES, LINES, HOSES, FITTINGS										
X20 00004	4730-249-1521	ELBOW, REDUCING: TANK FILL, 90 DEG, 2 IN. X 1 ½ IN.		EA		1				D1	17	
X20 00005	4720-289-6105	HOSE, COTTON, RUBBER LINED: TANK FILL., DC 1 ½ IN. DIA 50 FT LG		EA		1				D1	18	
P 0 00005A	5310-591-6865	CLAMP ASSEMBLY, SEALING		EA		1	*	*	*	*		
X20 00006		SPRAY BAR ASSEMBLY (97403) D13211E4370		EA		1				D2		
M 0 00007		BRACE, SPRAY BAR: LM (97403) 813216E8308		EA		1				D2	24	
X20 00008	9520-277-4913	MANUFACTURE FROM: ANGLE, STEEL (23 7/16 IN. REQUIRED)		FT			SEE GPP 9501					
M 0 00009		BRACE SPRAY BAR: RM (97403) B13216E8308		EA		1				D2	13	
X20 00010	9520-277-4913	MANUFACTURE FROM: ANGLE, STEEL (23 7/16 IN. REQUIRED)		FT			SEE GRP 9501					
X20 00011	4730-231-2129	CAP, PIPE: SPRAY BAR END (97403) 21NNOM		EA		2				D2	14	

(1) SMR CODE	(2) FEDERAL STOCK NUMBER	(3) DESCRIPTION REFERENCE NUMBER & MFR CODE USABLE ON CODE		U/I	(4) UNIT OF MEAS	(5) QTY. INC IN UNIT	(6) 15-DAY ORGANIZATIONAL MAINTENANCE ALW				(7) ILLUSTRATION	
							(a)	(b)	(c)	(d)	(a)	(b)
							1-5	6-20	21-50	51-100	FIGURE NO.	ITEM NO.
X20 00012		CHAIN TWIST SPRAY EAR RETAINER (97403) TYPE I GRADE C CLASS 5 (24 IN. LG)		EA		1					D2	22
X20 00013	4730-807-5241	CLAMP, HOSE: SPRAY OAR HOLE (96906) MS35842-3		EA		2					D2	8
X20 00014		ELBOW MALE, FEMALE, UNION: SPRAY BAR (97403) C13212E6904-6		EA		2					D2	18
X20 00015	4730-277-5643	ELBOW, PIPE: DRAIN (81336) 010756-1-13		EA		3					D2	6
M O 00016		HOSE, SPRAY BAR (97403) 2 1-21 D GRADE E MANUFACTURE FROM:		EA		1					D2	7
P O 00017	4720-189-2787	HOSE, RUBBER (20 1/2 IN. REQUIRED)		FT			SEE GRP	9501				
00018		NIPPLE, PIPE: SPRAY BAR TO TANK (97403) FCES824-22 (2 INCHES x 2 IN. LG)		EA		1					D2	1
X20 00019		NIPPLE, E5 RASS: VALVE TO UNION (97403) TYPE 1		EA		1					D2	3
M O 00020		NIPPLE, PIPE: ELBOW 10 HOSE (97403) 2 INNOMTYPE I MANUFACTURE FROM:		EA		2					D2	9
P O 00021	4710-162-1022	PIPE, STEEL: 2 IN. (5 IN. REQUIRED FOR EACH NIPPLE)		FT			SEE GRP	9501				
M O 00022		NIPPLE, PIPE: VALVE TO ELBOW (97403) 2 INNOMTYPE I MANUFACTURE FROM:		EA		1					D2	5
P O 00023	4710-162-1022	PIPE, STEEL: 2 IN. (3 IN. REQUIRED)		FT			SEE GRP	9501				
O 00024	5310-579-1867	NUT, PLAIN, HEXAGON: BRACE MTG		EA		4					D2	2

Page	Line	Action	1			2	3	4	5	6	7				8	
			Source maintenance and recoverability code			Federal stock No	Description	Unit of issue	Qty inc in unit pack	Qty inc in unit	15Day organizational maint allowances				Figure No.	Item or symbol No.
											1-5	6-20	21-50	51-100		
D-3	00004	Delete entry	X2	0		4730-249-1521										
	00004	Add entry	X2	0		NONE	EA		1	*	*	*	*	D-1	17	
	00005	Delete entry	X2	0		4720-289-6105										
	00005	Add entry	X2	0		4720-289-6103	EA		1	*	*	*	*	D-1	18	
	00007	Change colm 1,add colm 2 and change colm 3	P	0		3825912-3300	EA		1					D-2	24	
	00008	Delete entire entry	X2	0		9520-277-4913	*									
	00009	Change colm 1, add colm 2 and change colm 3	P	U		3825-912-3292	EA		1					D-2	13	
	00010	Delete entire entr	X2	0		9520-277-4913										
D6	00040	Change colm 3	X2	0		NONE	EA		1					D-2	4	

Page D-10. Figure D-1 is superseded as follows:

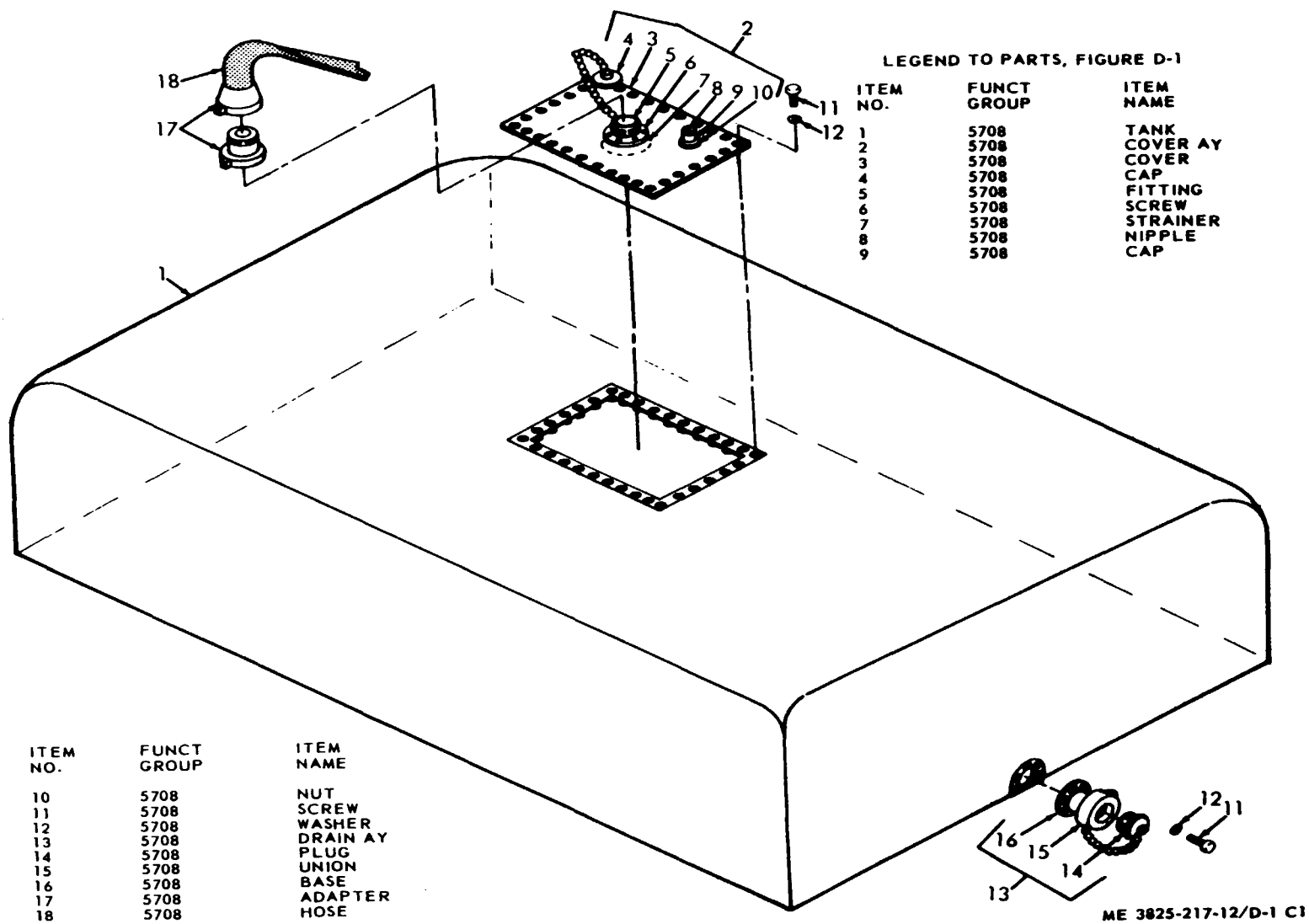
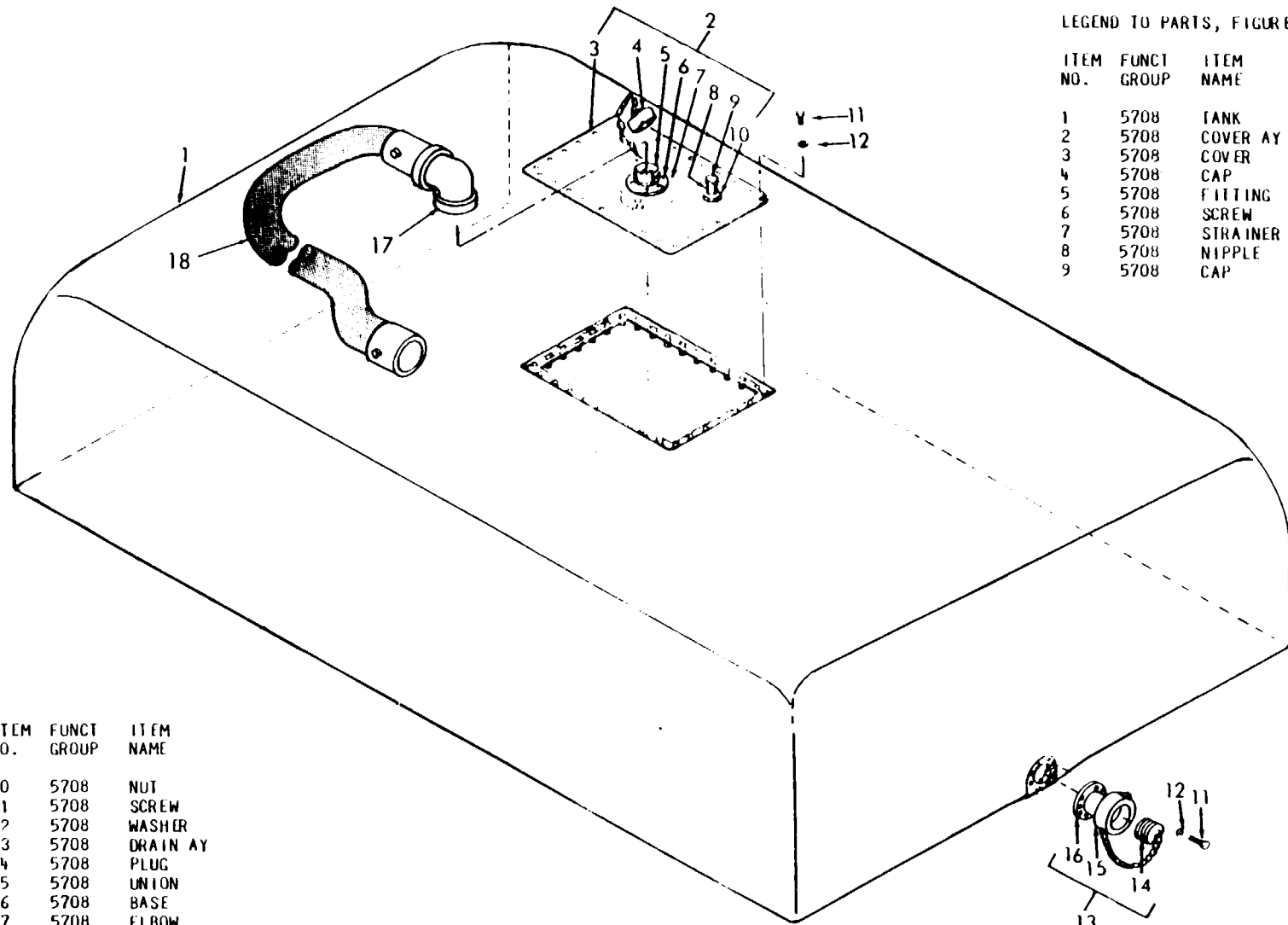

Figure D-1. Tank.

(1) SMR CODE	(2) FEDERAL STOCK NUMBER	(3) DESCRIPTION REFERENCE NUMBER & MFR CODE USABLE ON CODE		(4) UNIT OF MEAS	(5) QTY. INC IN UNIT	(6) 15-DAY ORGANIZATIONAL MAINTENANCE ALW				(7) ILLUSTRATION		
						(a)	(b)	(c)	(d)	(a)	(b)	
						1-5	6-20	21-50	51-100	FIGURE NO.	ITEM NO.	
0 00052	5310-616-3092	NUT, LOCK: NIPPLE MTG (97403) TYPEICLASS I		EA		2				D1	10	
0 00053		NHT, PLAIN, HEXAGON: CHAIN MTG (96906) Ms35619-45		EA		3						
00054	5305-207-4768	SCREW, MACHINE: FITTING MTG (9906) Ms35214-16 (4-40 THO siZe, 1/2 IN. LQ)		EA		6				D1	6	
00055	5305-637-5884	SCREW MACHINE: CHAIN MTG (96906) Ms35214-12		EA		3						
X20 00056	5310-591-3416	STRAINER, TANK FILL (97403) E13214E4362		EA		1				D1	7	
0 00057		WASHER FLAT: CHAIN MTG (96906) HS15795-904 (.125 ID, .312 oo, .032 THR)		EA		1						
X20 00058	5305-068-0505	DRAIN ASSEMBLY (97403) C13214E4375		EA		1				D1	13	
X20 000059		BASE, DRAIN (97403) C13214E4364		EA		1				D1	16	
X20 00060		UNION, DRAINCAIDI15 (97403) 2INCHIPS										
X20 000061		CHAIN, DRAIN PLUG: WELDLESS, FLAT LINK BRASS (97103) TYPEIICLASSII										
0 00062		PLUG, DRAIN: SQUARE HEAO, 2 IN. IPS (97403) TYPE1CLASS1		EA		1					D1	14
0 00063		SCREW, CAP, HEXAGON HEIA: MANHOLE COVER MTG (96906) tS9o726-5 (1/4-28 THO SIZE, .62 IN. LG)		EA		40					D1	11
X20 000064		5310-965-1803	TANK NYLON (97403) I32z14E4265		EA		1				D1	1
0 000065			WASHER, FLAT:MNANHOLE COVER MTG (96906) ms15795-810 (.261 10, .625 00, .065 IN. THK)		EA		32				D1	12

(1) SMR CODE	(2) FEDERAL STOCK NUMBER	(3) DESCRIPTION REFERENCE NUMBER & MFR CODE USABLE ON CODE		U/I	(4) UNIT OF MEAS	(5) QTY. INC IN UNIT	(6) 15-DAY ORGANIZATIONAL MAINTENANCE ALW				(7) ILLUSTRATION	
							(a)	(b)	(c)	(d)	(a)	(b)
							1-5	6-20	21-50	51-100	FIGURE NO.	ITEM NO.
O 000666	5310-827-8381	WASHER, LOCK: NANHOLE COVER MTG (96906) MS35338-82 (1/4 IN. SCREW SIZE)			EA	8						
P 0 000067	3825-798-1144	REPAIR KIT COI.LAPSIBLE FABRIC TANK (89616) RK41			EA	1	*	*	2			
X1 000068		ACCELERATOR, RUBBER (00333) 3259			EA	6						
X1 000069	8020-260-1305	ADHESIVE (00333) 3289			EA	6						
X1 00070		BRUSH (89616) RK41-2			EA	1						
X1 00071		CAN, FRICTION TOP			EA	1						
X1 00072		CEMENT, AIR CURING: 1/2 PT (89616) RKI1-1			EA	6						
X1 00073	5340-591-6863	CHEESE CLOTH SPEC CCC-C-271 (89616) RK41-3 (26 IN. w, 6 FT LG)			EA	1						
X1 00074		CLAMP ASSEMBLY, SEALING (89616) RK4I-8			EA	2						
X1 00075		5310-391-686	CLAW ASSEMBLY, SEALING (89616) RK41-9			EA	1					
X1 00076			CLOTH, COATED, MIL-D-52033 (89616) RK4 1-4 (12 IN. , 6 FT LO)			EA	1					
X1 00077		CLOTH, EMERY: 180 GRIT No. 6/o (9 IN. w, 11 IN. LO)			SH	6						
X1 00078		GUM STRIP (1 IN. W, 6 FT LG)			EA	1						
X1 00079		INSTRUCTIONS, REPAIR (89616) RK41-7			EA	1						

(1) SMR CODE	(2) FEDERAL STOCK NUMBER	(3) DESCRIPTION REFERENCE NUMBER & MFR CODE USABLE ON CODE		U/I	(4) UNIT OF MEAS	(5) QTY. INC IN UNIT	(6) 15-DAY ORGANIZATIONAL MAINTENANCE ALW				(7) ILLUSTRATION	
							(a) 1-5	(b) 6-20	(c) 21-50	(d) 51-100	(a) FIGURE NO.	(b) ITEM NO.
X1 00080	5120-243-9402	ROLLER, HAND (89616) RK41-5 (2 IN. WIDE)		EA		1						
00081 00081A		GROUP 95 - GENERAL USE STANDARDIZED PARTS 9501 - BULK MATERIAL										
X20 00082	9520-277-4913	ANGLE, STEELE		FT								
P 0 00083	4720-180-2787	HOSE, RUBBER		FT			*	*	2	2		
P 0 00084	4710-162-1022	PIPE, STEEL: 2 IN		FT			*	*	*	*		
P 0 00085	4020-965-0378	ROPE, NYLON		FT			2	5	10	21		



LEGEND TO PARTS, FIGURE D-1

ITEM NO.	FUNCT GROUP	ITEM NAME
1	5708	TANK
2	5708	COVER AY
3	5708	COVER
4	5708	CAP
5	5708	FITTING
6	5708	SCREW
7	5708	STRAINER
8	5708	NIPPLE
9	5708	CAP

ITEM NO.	FUNCT GROUP	ITEM NAME
10	5708	NUT
11	5708	SCREW
12	5708	WASHER
13	5708	DRAIN AY
14	5708	PLUG
15	5708	UNION
16	5708	BASE
17	5708	ELBOW
18	5708	HOSE

ME 3825-217-15/D-1

Figure No. D-1 Tank

LEGEND TO PARTS, FIGURE D-2

ITEM NO.	FUNCT GROUP	ITFM NAME
1	5708	NIPPLE
2	5708	UNION
3	5708	NIPPLE
4	5708	VALVE
5	5708	NIPPLE
6	5708	ELBOW
7	5708	HOSE
8	5708	CLAMP
9	5708	NIPPLE
10	5708	U-BOLT
11	5708	WASHER
12	5708	NUT
13	5708	BRACE
14	5708	CAP
15	5708	PIPE
16	5708	NUT
17	5708	WASHER
18	5708	ELBOW
19	5708	RING
20	5708	SCREW
21	5708	PIPE
22	5708	CHAIN
23	5708	TEE
24	5708	BRACE
25	5708	ROPE

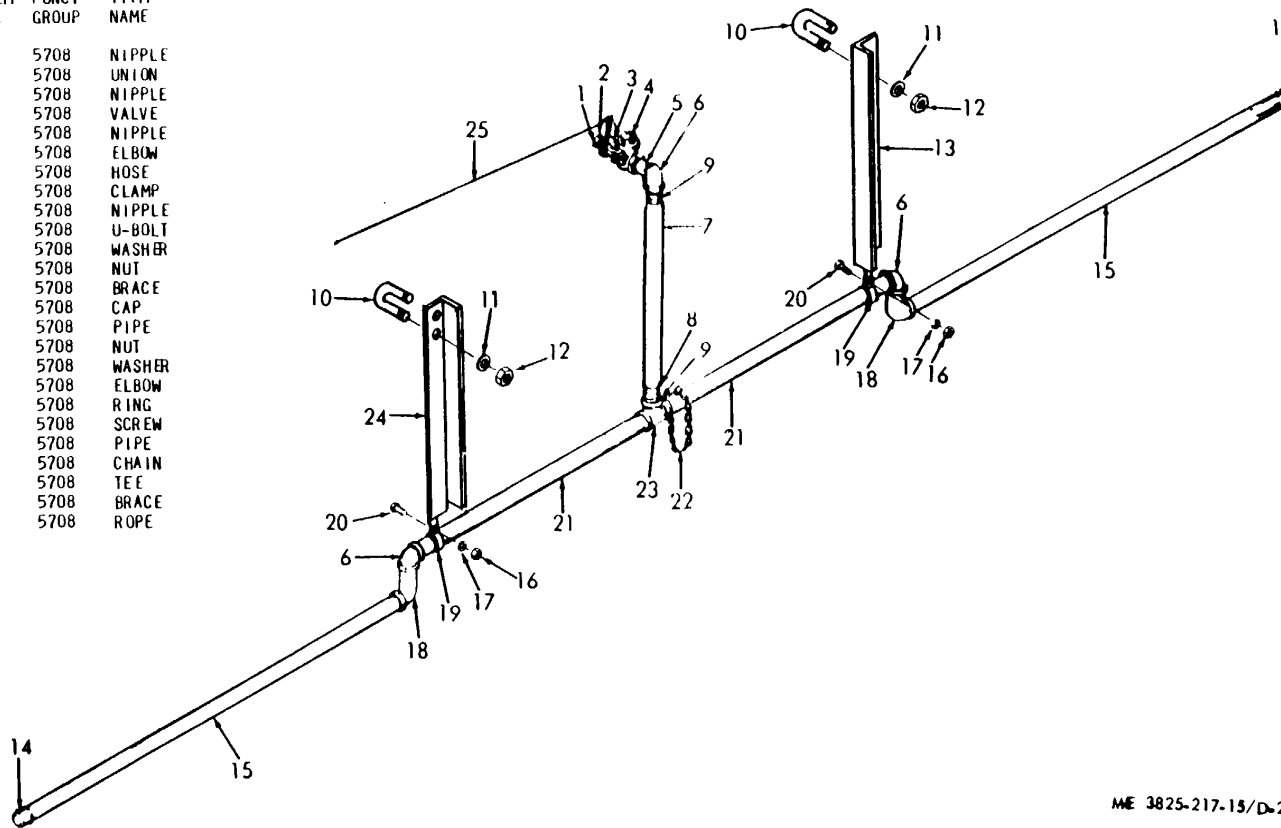

ME 3825-217-15/D-2

Figure No. D-2 Spray Bar
9

**Section V. INDEX FEDERAL STOCK NUMBER AND REFERENCE NUMBER
CROSS-REFERENCE TO INDEX NUMBER**

<u>STOCK NUMBER</u>	<u>INDEX NUMBER</u>	<u>STOCK NUMBER</u>	<u>INDEX NUMBER</u>
3825-798-1134	00047	5305-207-7468	00035
3825-798-1144	00067	5305-637-5884	00055
4020-965-0378	00033	5306-425-0469	00038
	00085	5310-579-1867	00024
4710-162-1022	00021	5310-591-3416	00057
	00023	5310-616-3092	00053
	00028	5310-688-1601	00041
	00030	5310-732-0558	00025
	00084	5310-814-4594	00026
4720-180-2787	00083	5310-965-1803	00065
4720-189-2787	00017	5340-391-6864	00075
4720-289-6105	00005	5340-591-6863	00074
4730-231-2429	00011	5340-591-6865	00005
4730-249-1521	00004	8020-260-1305	00070
4730-277-5643	00015	9520-277-4913	00008
4730-807-5241	00013		00010
5120-243-9402	00080		00082
5305-068-0505	00063	9905-807-3715	00002
5305-207-4768	00054		

<u>REFERENCE NO.</u>	<u>MFG CODE</u>	<u>INDEX NUMBER</u>	<u>REFERENCE NO.</u>	<u>MFG CODE</u>	<u>INDEX NUMBER</u>
B12314E4367	97403	00045	RK41	89616	00067
B13214E4362	97403	00056	RK41-1	89616	00072
B13214E4373	97403	00031	RK41-2	89616	00070
B13216E8308	97403	00007	RK41-3	89616	00073
		00009	RK41-4	89616	00076
C13214E4363	97403	00040	RK41-5	89616	00080
C13214E4364	97403	00059	RK41-7	89616	00079
C13214E4366	97403	00049	RK41-8	89616	00074
C13214E4375	97403	00058	RK41-9	89616	00075
C13214E6257	97403	00048	TYPE1	97403	00019
C13212E6904-6	97403	00014			00051
CLASSB			TYPE1CLASS1	97403	00052
D10756-1-13	81336	00015			00062
D13214E4265	97403	00064	TYPE11CLASS11	97403	00061
D13214E4370	97403	00006	TYPE11CLASS4	97403	00050
D13214E6255	97403	00043	TYPE1GRADECCCLASS5	97403	00012
D13214E6256	97403	00044	2 1-21GRADEB	97403	00016
FCE50824-22	97403	00018	2INCHIPS	97403	00060
MS15795-810	96906	00065	2INIPS	97403	00039
MS15795-904	96906	00057	2INNOM	97403	00011
MS34338-8	96906	00042			00027
MS35214-12	96906	00055			00029
MS35214-16	96906	00035			00037
		00054	2INNOMTYPE1	97403	00020
MS35338-6	96906	00041			00022
MS35338-82	96906	00066	3-8INCHSIZE	97403	00036
MS35649-45	96906	00026	3256	00333	00068
		00053	3289	00333	00069
MS35690-601	96906	00025			
MS35842-3	96906	00013			
MS90726-5	96906	00063			

By Order of the Secretary of the Army:

Official:

KENNETH G. WICKHAM,
*Major General, United States Army,
The Adjutant General.*

W. C. WESTMORELAND,
*General, United States Army,
Chief of Staff.*

Distribution:

To be distributed in accordance with DA Form 12-25, Section II, (qty rqr block no. 378) Organizational Maintenance requirements for Distributors, Water.

*U.S. GOVERNMENT PRINTING OFFICE: 1969-342-016/2629

US ARMY ADJUTANT GENERAL PUBLICATIONS CENTER, ST. LOUIS, MO 1985

RECOMMENDED CHANGES TO EQUIPMENT TECHNICAL PUBLICATIONS



THEN... JOT DOWN THE DOPE ABOUT IT ON THIS FORM, CAREFULLY TEAR IT OUT, FOLD IT AND DROP IT IN THE MAIL!

SOMETHING WRONG WITH THIS PUBLICATION?

FROM: (PRINT YOUR UNIT'S COMPLETE ADDRESS)

DATE SENT

PUBLICATION NUMBER

TM 11-5825-270-10

PUBLICATION DATE

23 Jul 81

PUBLICATION TITLE

Radio Frequency R-2176/FRN

BE EXACT... PIN-POINT WHERE IT IS

PAGE NO.	PARA-GRAPH	FIGURE NO.	TABLE NO.
----------	------------	------------	-----------

IN THIS SPACE TELL WHAT IS WRONG AND WHAT SHOULD BE DONE ABOUT IT:

TEAR ALONG PERFORATED LINE

PRINTED NAME, GRADE OR TITLE, AND TELEPHONE NUMBER

SIGN HERE:

DA FORM 2028-2
1 JUL 79

PREVIOUS EDITIONS
• ARE OBSOLETE.

P.S.—IF YOUR OUTFIT WANTS TO KNOW ABOUT YOUR RECOMMENDATION MAKE A CARBON COPY OF THIS AND GIVE IT TO YOUR HEADQUARTERS.

THE METRIC SYSTEM AND EQUIVALENTS

WEIGHT MEASURE

1 Centimeter = 10 Millimeters = 0.01 Meters = 0.3937 Inches
 1 Meter = 100 Centimeters = 1000 Millimeters = 39.37 Inches
 1 Kilometer = 1000 Meters = 0.621 Miles

WEIGHTS

1 Gram = 0.001 Kilograms = 1000 Milligrams = 0.035 Ounces
 1 Kilogram = 1000 Grams = 2.2 lb.
 1 Metric Ton = 1000 Kilograms = 1 Megagram = 1.1 Short Tons

LIQUID MEASURE

1 Milliliter = 0.001 Liters = 0.0338 Fluid Ounces
 1 Liter = 1000 Milliliters = 33.82 Fluid Ounces

SQUARE MEASURE

1 Sq. Centimeter = 100 Sq. Millimeters = 0.155 Sq. Inches
 1 Sq. Meter = 10,000 Sq. Centimeters = 10.76 Sq. Feet
 1 Sq. Kilometer = 1,000,000 Sq. Meters = 0.386 Sq. Miles

CUBIC MEASURE

1 Cu. Centimeter = 1000 Cu. Millimeters = 0.06 Cu. Inches
 1 Cu. Meter = 1,000,000 Cu. Centimeters = 35.31 Cu. Feet

TEMPERATURE

$5/9(^{\circ}\text{F} - 32) = ^{\circ}\text{C}$
 212° Fahrenheit is equivalent to 100° Celsius
 90° Fahrenheit is equivalent to 32.2° Celsius
 32° Fahrenheit is equivalent to 0° Celsius
 $9/5^{\circ}\text{C} + 32 = ^{\circ}\text{F}$

APPROXIMATE CONVERSION FACTORS

TO CHANGE	TO	MULTIPLY BY
Inches	Centimeters	2.540
Feet	Meters	0.305
Yards	Meters	0.914
Miles	Kilometers	1.609
Square Inches	Square Centimeters	6.451
Square Feet	Square Meters	0.093
Square Yards	Square Meters	0.836
Square Miles	Square Kilometers	2.590
Acres	Square Hectometers	0.405
Cubic Feet	Cubic Meters	0.028
Cubic Yards	Cubic Meters	0.765
Fluid Ounces	Milliliters	29.573
its	Liters	0.473
arts	Liters	0.946
allons	Liters	3.785
Ounces	Grams	28.349
Pounds	Kilograms	0.454
Short Tons	Metric Tons	0.907
Pound-Feet	Newton-Meters	1.356
Pounds per Square Inch	Kilopascals	6.895
Miles per Gallon	Kilometers per Liter	0.425
Miles per Hour	Kilometers per Hour	1.609

TO CHANGE	TO	MULTIPLY BY
Centimeters	Inches	0.394
Meters	Feet	3.280
Meters	Yards	1.094
Kilometers	Miles	0.621
Square Centimeters	Square Inches	0.155
Square Meters	Square Feet	10.764
Square Meters	Square Yards	1.196
Square Kilometers	Square Miles	0.386
Square Hectometers	Acres	2.471
Cubic Meters	Cubic Feet	35.315
Cubic Meters	Cubic Yards	1.308
Milliliters	Fluid Ounces	0.034
Liters	Pints	2.113
Liters	Quarts	1.057
ers	Gallons	0.264
ms	Ounces	0.035
ograms	Pounds	2.205
Metric Tons	Short Tons	1.102
Newton-Meters	Pounds-Feet	0.738
Kilopascals	Pounds per Square Inch	0.145
ometers per Liter	Miles per Gallon	2.354
ometers per Hour	Miles per Hour	0.621



PIN: 005503-002